



**UMANG PHARMATECH PVT. LTD.**

Quotation	<b>Umang Batch Mixer/Granulator- 4200</b>	
Client name		
Quotation No.	1687, Revision 1	
Date	12/12/05	
Validity	90 days.	Replaces :
Kind Attn.		

610-

*Umang mixing equipments.*

**More than 600 equipment systems performing across  
the globe in more than 30 countries**

*Equipment : Mixerr Granulator - 4200*

*for mixing / making granules.*

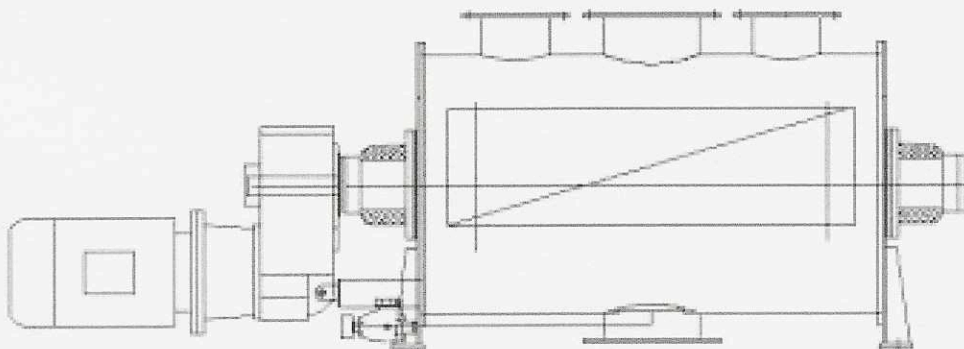



**UMANG PHARMATECH PVT. LTD.**

Quotation	<b>Umang Batch Mixer/Granulator- 4200</b>	
Client name		
Quotation No.	1687, Revision 1	
Date	12/12/05	
Validity	90 days.	Replaces :
Kind Attn.		

**Dear Mr.**

We are pleased to present you with the following revised quotation for an Umang Mixer/Granulator as requested with those options included that have been determined by Global Synfrac to be required.

This proposal incorporates all dimensions as shown in attached drawings.

Please consult us for requirements not listed in this proposal.

**(A) TECHNICAL SPECIFICATIONS**

**4200 Litre Mixer/Granulator.**

Parameter	Specification.	Operational specification
Volume	Total : 4,200 L	Usable : 1,000 – 3,000 ltrs.
Internal parameters	Internal Pressure: 0.8 to 1 Bara	Temperature : - 0 deg. C. To 100 deg. C.
Mixer drum	Diameter: 51 inches ID Length : 126 inches	With base plates & lifting carbon steel.
M.O.C.	Product Contact Parts: 304 SS Process Wetted; Carbon Steel remainder	Bearing housing & drive Carbon Steel
Surface	Inside 120 grit Outside glass bead blasted	Bearing housing & drive varnished RAL 5018.
ASME Code Stamped Water Jacket Parameters	Pressure: Max: 75 PSIG Normal: 45 psig	Temperature: Max: 100 deg C. Normal: 20 deg C. Minimum: 0 deg C.
Mixing shaft	Horizontal shaft with modified plough shears shovels	8 Shovel arms bolted to the shaft. Treated for wear resistance.
MS Sealing	Stuffing Box packing.	Chamber for optional sealing medium (pressured air).
MS Bearing	Roller bearings in bearing lantern	Separate sealing and bearing
MS drive	Falk Gear motor Nominal power: CSA approved 250 HP	Variable speed inverter controlled drive for main shaft
Discharge door	Flush fitting door sealed with silicone gasket.	Integrated in discharge nozzle, manual operation.
Discharge nozzle		Open nozzle; contains discharge door.
Inspection nozzle	At Mixer front; Manual Operation	With Interlocking of magnet (For operator safety)
Chopper	5 x closed with flush fitting plug	X type choppers. Treated for wear resistance. Each with CSA approved 10 HP drive.
Electrical	460 V / 60 Hz. / 3 Phase	
Controls	Rockwell PLC Compac Logics 1769L31 with 2711K5/A16L1 keypad based control system, NEMA 4 approved	MODbus communications



**UMANG PHARMATECH PVT. LTD.**

Quotation	<b>Umang Batch Mixer/Granulator- 4200</b>	
Client name		
Quotation No.	1687, Revision 1	
Date	12/12/05	
Validity	90 days.	Replaces :
Kind Attn.		

**(B) PRICING**

**Umang Mixer/Granulator - 4200**  
**Process Wetted in S.S. 304, rest M.S.**  
**Configured as above:**

**CIF Alberta, CA, duty paid**  
**US Dollars 142,875**

**(C) SITE SUPPORT**

**Installation assistance at customer site (Charges per day):**                    **USD    500.00**  
**To & fro Travel expenses will be charged extra as applicable.**

**Additional Notes**

For specialty skills that require personnel outside of Umang's and/or a third party contractor, different hourly rates may apply. These rates will be defined on a separate per job basis.

**(D) ADDITIONAL INFORMATION**

**I. START-UP ASSISTANCE**

Umang can provide on site engineering support to provide technical assistance during your installation of the system and to commission the installed equipment to verify its' proper installation & operation.

Assistance is available at Umang's standard technical service rates. Installation engineering, construction management & equipment installation, customized formal training programs, calibration and validation services are also available from Umang. Please contact us for further details.

**II. FACTORY INSPECTIONS**

The customer is always welcome to attend a final inspection of the equipment at our Indian manufacturing site.

**III. LEAD TIME**

Lead time is 45 days exworks Mumbai shop.

**IV. SHIPMENT**

All foreign manufactured equipment costs include sea freight costs to the F.O.B. point stated on page 1, customs clearance charges, duty charges, and handling charges at the port of entry. All Indian manufactured equipment costs are F.O.B. originating factory site.

**V. CANCELLATION**

All orders are subject to cancellation charges as defined in a cancellation schedule, which will be defined as system specifications and lead time become final.



**UMANG PHARMATECH PVT. LTD.**

Quotation	Umang Batch Mixer/Granulator- 4200	
Client name		
Quotation No.	1687, Revision 1	
Date	12/12/05	
Validity	90 days.	Replaces :
Kind Attn.		

**(F) TERMS AND CONDITIONS OF SALE**

- 1. Prices** : Quoted are valid for 90 days from the date of Quotation. CIF Alberta, CA, Duty paid.
- 2. Terms of Payment** : 50% advance, 40% at time of shipment against Proforma Invoice, and remaining 10% at time of delivery.
- 3. Documents** : One set of manual and drawing will be provided.  
The manual shall contain operating instructions, cleaning procedure, essential spare parts list, trouble shooting and circuit diagram.
- 4. Installation charge:** Extra as applicable, as described in technical fees structure.
- 5. Guarantee** : 12 months from the date of commissioning of PLANT or 18 months from the date of delivery at SITE whichever is earlier.  
Wear & tear parts like bearings, oil seals, etc. are not included within the scope of warranty.
- 6. Delivery Schedule** : exworks 45 days after receipt of firm Purchase Order.

Export of these commodities from India is administered in accordance with the Export administration Regulations. Shipment of the order is subject to compliance with Indian Export Rules and diversion contrary to which is prohibited.

**PROPRIETARY NOTICE**

The contents of and information contained in this quotation, including but not limited to all prices and technical data are proprietary to and the exclusive property of Umang Pharmatech Pvt. Ltd. India. The information contained herein is confidential and shall not, without the prior written permission of Umang Pharmatech., be used, released or disclosed, in whole or in part, to any third party. This notice shall be included on any reproduction hereof.

We hope that the offer suits your requirement & we will get a positive reply from your end soon.

Thanking you.

Best Regards.

For **UMANG PHARMATECH PVT. LTD.**

**U. BUDHRAJA**  
(VICE PRESIDENT - SALES)